

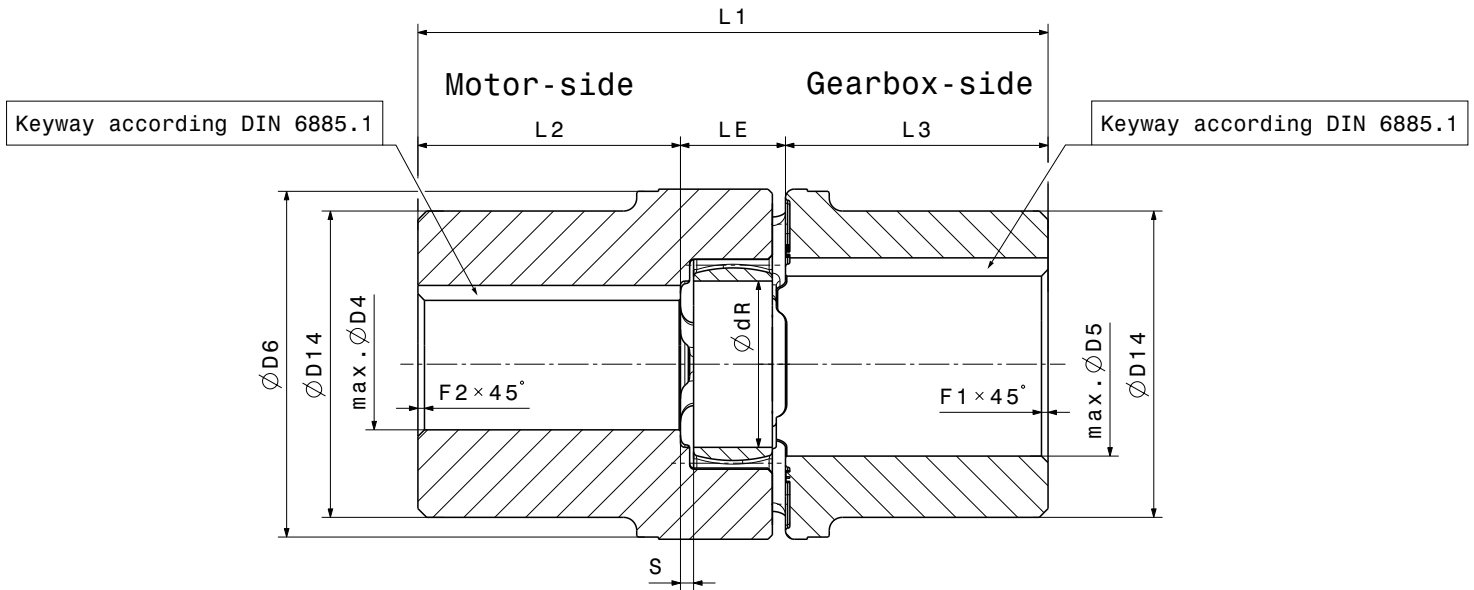

FLEXIBLE COUPLING ALC-A

M 1501 338 E-EN-2008-02



Type ALC-A	T_{kn} Nm	T_{kmax} Nm	n_{max} min ⁻¹	ØD4 ØD5 pilot bore	ØD4 max	ØD5 max	ØD6	ØD14	ØdR	L1	L2	L3	LE	S	F1 F2 x45°	I_{ges} kgm ²	G_{ges} kg
38	325	650	8300	-	42	42	80	70	38	144	60	60	24	3	1,5	0,002	2,4
42	450	900	7000	-	50	50	95	80	46	166	70	70	26	3	1,5	0,004	3,8
48	525	1050	6400	-	55	55	105	90	51	178	75	75	28	3,5	2	0,008	5,8
55	685	1370	5600	18	65	65	120	105	60	200	85	85	30	4	2	0,014	7,7
65	940	1880	4950	18	70	70	135	115	68	235	100	100	35	4,5	2,5	0,027	11,5
75	1920	3840	4200	28	80	80	160	135	80	270	115	115	40	5	2,5	0,059	18,7
90	3600	7200	3350	38	100	100	200	160	100	315	135	135	45	5,5	3	0,152	32
100	4950	9900	3000	38	110	110	225	180	113	350	150	150	50	6	3	0,270	45
110	7200	14400	2600	48	125	125	255	200	127	375	160	160	55	6,5	3	0,471	62
125	10000	20000	2300	48	140	140	290	230	147	430	185	185	60	7	3	0,916	93

When selecting the coupling assembly, setting and maintenance instructions have to be observed. Other dimensions upon request. Individual balancing of coupling components available upon request. Axial fixing of coupling hub possible with set-screw above the key upon request. Weight and inertia indicated for max. bore ØD4 and ØD5.