

HYDRAULIC RAIL PUSHER

RPS 450

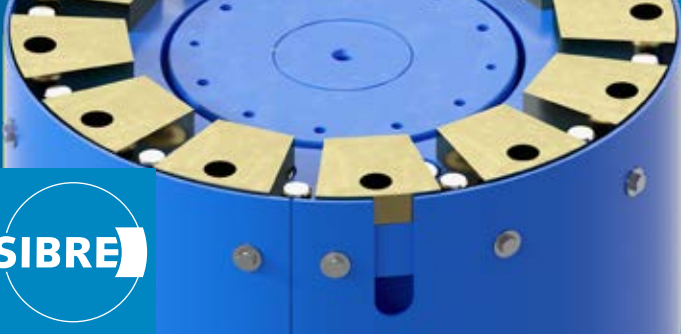

M 1501 354 E-EN-2017-10

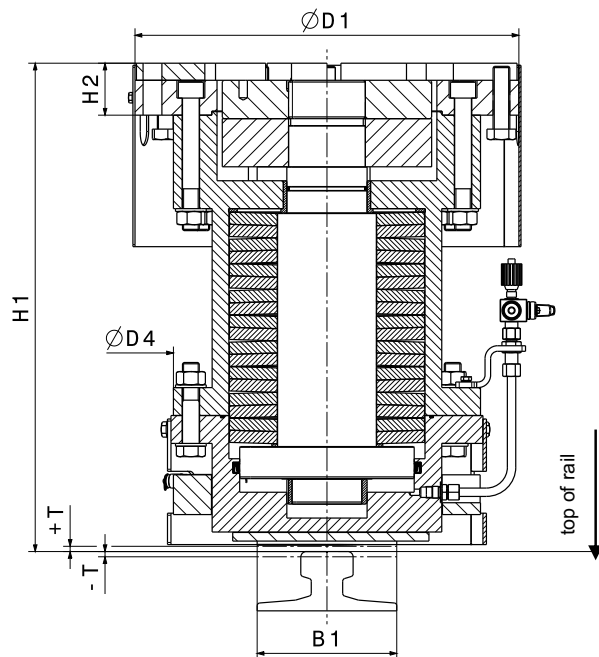
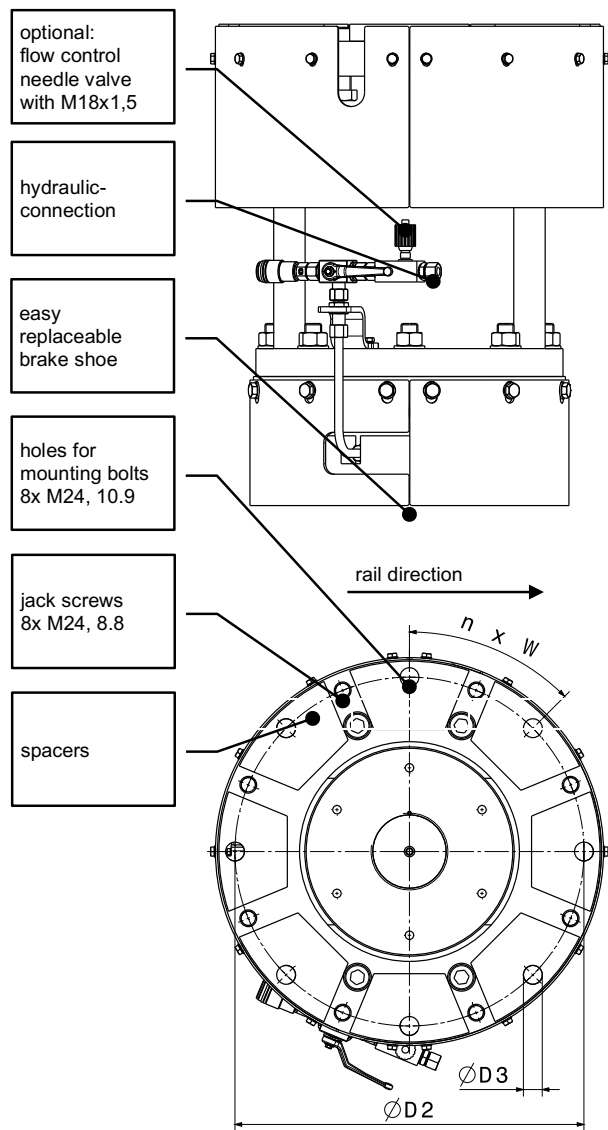

HYDRAULIC DATA:

medium: HLP-hydraulic oil DIN 51524-T2
HLP Synth 32 standard

temperature range: [-15°C.....+40°C]

we recommend: SIBRE-hydraulic power pack V3.D *) for RPS 450
with electronic control box acc. data sheet M 1501 264 E

*) max. 4 brakes per power pack
dimensional drawings upon request

Type	H1 mm	H2 mm	B1 mm	+T mm	-T mm	D1 mm	D2 mm	D3 mm	D4 mm	W1	n x W
RPS 450	700	74,5	200	+7,5	-7,5	550	500	27	457	-	8 x 45°
Type	Holding force	Holding force at max. rail tolerance		Release pressure	max. operating pressure	Hydraulic-connection	Weight				
		+T	-T								
RPS 450	225 kN	299 kN	148 kN	145 bar	175 bar	1/2"	670 kg				