

# DRUM BRAKE TE

M 900 1000 E-EN-2008-02

acc. to DIN 15435 | spring applied, thruster released

option: lining wear compensator

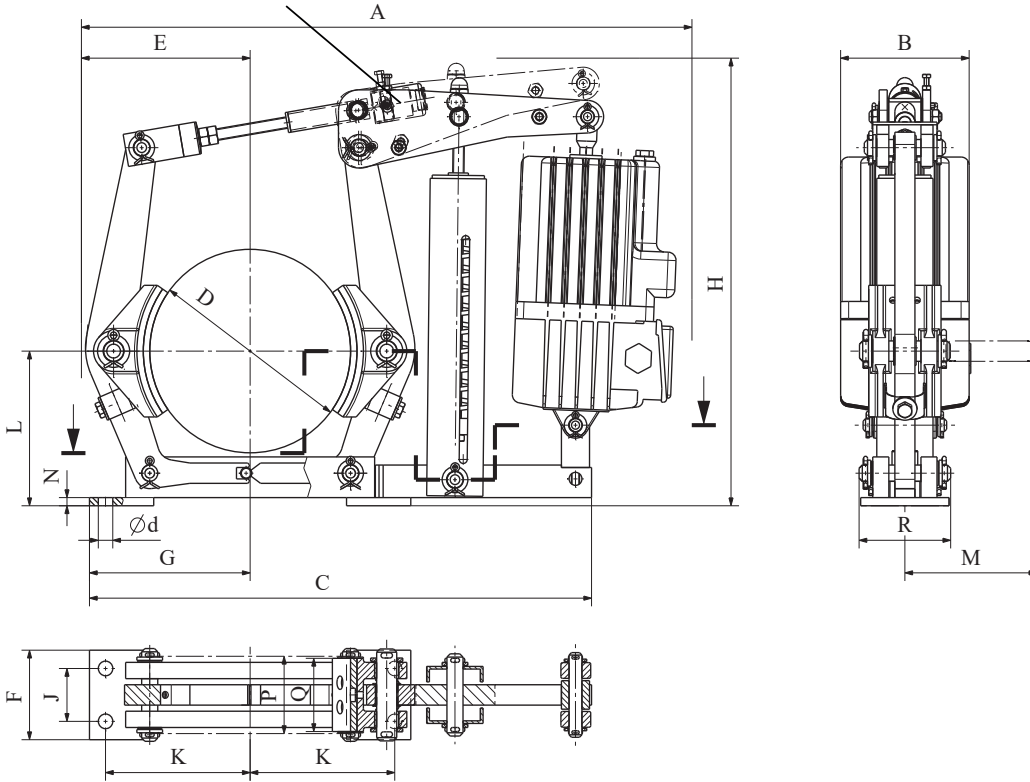

## WHEN ORDERING PLEASE ADVISE:

- brake type and thruster  
e.g. TE 250/23/5
- power supply voltage  
for thruster
- with our without lining wear  
compensator
- options

## THRUSTER SIZES

1 = Ed 23/5	10 = EB 220-50
2 = Ed 30/5	20 = EB 300-50
3 = Ed 50/6	30 = EB 500-60
4 = Ed 80/6	40 = EB 800-60
5 = Ed 121/6	50 = EB 1250-60
6 = Ed 201/6	60 = EB 2000-60
7 = Ed 301/6	70 = EB 3000-60

BRAKE-TYPE	Thruster SIZE	TORQUE RANGE in Nm at $\mu = 0,4$	A	B	C	D	E	F	G	H	J	K	L	M	N	P	Q	R	d	kg*
TE 200	1 / 10	50 - 300	640	160	515	200	170	90	160	475	55	145	160	115	10	75	70	96	14	19
	2 / 20	85 - 400	640	160						475										
TE 250	1 / 10	40 - 325	760	160	625	250	210	110	200	550	65	180	190	133	10	95	90	113	18	30
	2 / 20	40 - 450	760	160						560										
TE 315	1 / 10	70 - 420	885	160	735	315	260	125	240	650	80	220	230	160	10	118	110	135	18	50
	2 / 20	70 - 550	885	160						650										
	3 / 30	75 - 1050	925	195						660										
	4 / 40	90 - 1700	925	195						660										
TE 400	2 / 20	80 - 575	1030	160	900	400	310	160	300	765	100	270	280	199	12	150	140	167	22	85
	3 / 30	100 - 1100	1075	195						775										
	4 / 40	100 - 1800	1075	195						775										
	5 / 50	125 - 2750	1075	240						775										
TE 500	3 / 30	200 - 1400	1225	195	1025	500	385	190	355	870	130	325	340	242	13	190	180	202	22	130
	4 / 40	200 - 2200	1225	195						870										
	5 / 50	200 - 3400	1215	240						870										
	6 / 60	200 - 5400	1215	240						870										
TE 630	5 / 50	500 - 3300	1365	240	1190	630	465	250	440	1000	170	400	420	295	15	236	225	244	27	206
	6 / 60	500 - 5500	1365	240						1000										
	7 / 70	500 - 8200	1365	240						1000										
TE 710	5 / 50	500 - 3800	1500	240	1302	710	525	270	490	1100	190	450	470	332	15	265	255	276	27	268
	6 / 60	500 - 6300	1500	240						1100										
	7 / 70	500 - 9400	1500	240						1100										

\* kg without thruster