

SHOE BRAKE

TM-I 40 – TM-I 60



M 1501 372 E-EN-2010-03

spring applied, solenoid released | per AISE 11 standard

option:
wear compensator device

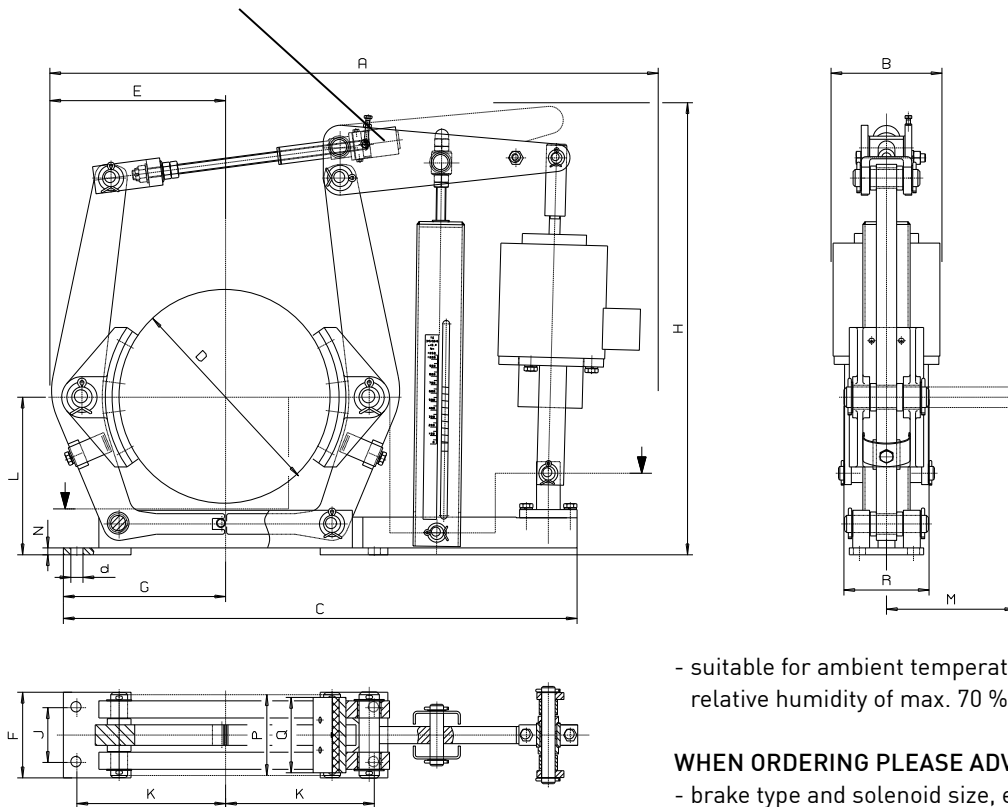

- suitable for ambient temperature range of 0 – 40° C and relative humidity of max. 70 % non-condensating.

WHEN ORDERING PLEASE ADVISE:

- brake type and solenoid size, e.g. TM-I-40-13-GH160
- with or without wear compensator device
- options
- input voltage for SCU

BRAKE-TYPE	SOLE-NOID SIZE	TORQUE RANGE IN NM AT $\mu = 0,4$	A	B	C	D	E	F	G	H	J	K	L	M	N	P	Q	R	d	kgs*		
TM-I 8	GH 140	50 – 300	640	160	515	203	170	190	160	475	146	83	178	115	10	83	76	96	17,5	19		
TM-I-10	GH 140	40 – 325	760	160	595	254	210	202	170	570	158	102	213	133	33	95	89	113	17,5	30		
	GH 160	40 – 450								580												
TM-I 13	GH 140	70 – 550	885	160	700	330	260	286	206	650	228	146	251	160	37	146	140	135	21,5	50		
	GH 160	75 – 1050	925	195						660												
TM-I 16	GH 140	80 – 575	1030	160	860	406	315	328	260	765	274	190	308	199	32	172	165	167	26	85		
	GH 160	100 – 1100	1075	195						775												
	GH 180	100 – 1800		240																		
TM-I 19	GH 160	200 – 1400	1225	195	1025	482	385	419	292	870	330	235	337	242	13	222	216	202	27	130		
	GH 180	200 – 2300																			1215	240
	GH 215	200 – 3400																				
TM-I 23	GH 215	500 – 3300	1365	240	1190	584	465	485	388	1000	406	298	403	295	15	286	279	244	33	206		
	GH 245	500 – 5500																				

The solenoids used for operation of shoe brakes TM-I are to be connected via SCU solenoid control unit SCU as per data sheet M 1501376, page 1+2. Indicated torques are only available in combination with SCU.

* kg without thruster

spring applied, solenoid released | per AISE 11 standard

option:
wear compensator device

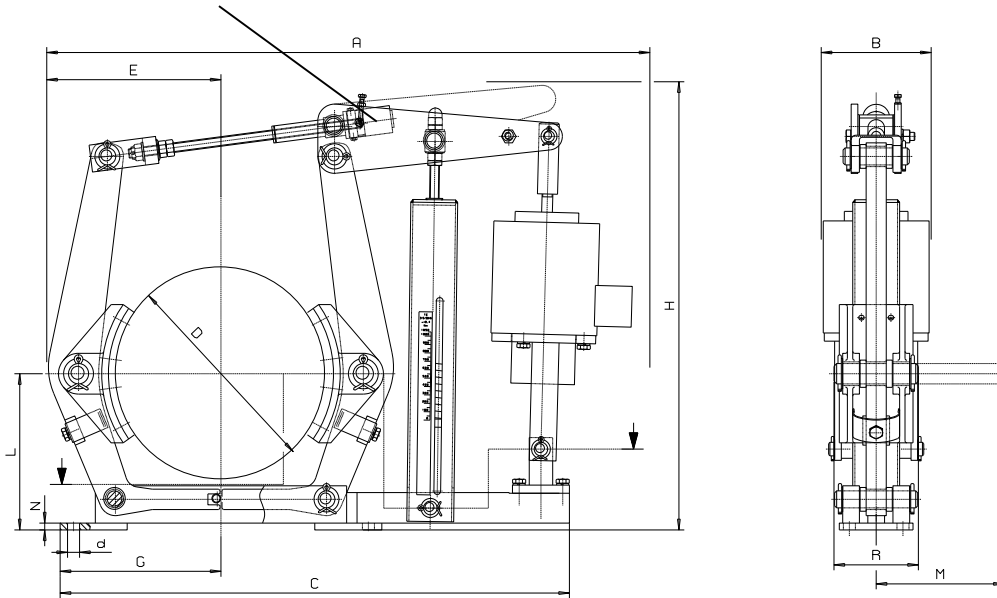

- suitable for ambient temperature range of 0 – 60° C and relating humidity of max. 70 % non-condensating.

WHEN ORDERING PLEASE ADVISE:

- brake type and solenoid size and torque, e.g. TM-I-60-13-GH160
- with or without wear compensator device
- options
- input voltage for SCU

BRAKE-TYPE	SOLE-NOID SIZE	TORQUE RANGE IN NM AT $\mu = 0,4$	A	B	C	D	E	F	G	H	J	K	L	M	N	P	Q	R	d	kg*
TM-I 8	GH 140	50 – 300	640	160	515	203	170	190	160	475	146	83	178	115	10	83	76	96	17,5	19
TM-I-10	GH 140	40 – 325	760	160	595	254	210	202	170	570	158	102	213	133	33	95	89	113	17,5	30
	GH 160	40 – 450								580										
TM-I 13	GH 140	70 – 550	885	160	700	330	260	286	206	650	228	146	251	160	37	146	140	135	21,5	50
	GH 160	75 – 1050	925	195						660										
TM-I 16	GH 140	80 – 575	1030	160	860	406	315	328	260	765	274	190	308	199	32	172	165	167	26	85
	GH 160	100 – 1100	1075	195						775										
	GH 180	100 – 1800	1075	240						775										
TM-I 19	GH 160	200 – 1400	1225	195	1025	482	385	419	292	870	330	235	337	242	13	222	216	202	27	130
	GH 180	200 – 2300																		
TM-I 23	GH 215	500 – 3300	1365	240	1190	584	465	485	388	1000	406	298	403	295	15	286	279	244	33	206
	GH 245	500 – 5500																		

The solenoids used for operation of shoe brakes TM-I are to be connected via SCU solenoid control unit SCU as per data sheet M 1501376, page 1+2. Indicated torques are only available in combination with SCU.

* kg without thruster